

Standard-Duty Piling Bracket Installation

1. Loosely attach two hardware connectors to the bottom of the adjustable piling bracket.
2. Place two hardware connectors into the top pockets of the dock section where the piling bracket is to be installed.
3. Next, guide the bracket and previously installed bottom hardware connectors (tapered side up) so that the bottom connectors are brought up and fully seated into the bottom pockets.
4. Move the bracket in towards the dock so the top two hardware connectors align with the mount holes in the bracket.
5. Secure the bracket to the dock by fully threading the enclosed 5/8" lock nuts. Install piling, and if using existing piling, make sure that the hoop can go around piling and mount into hoop mount holes on each side.

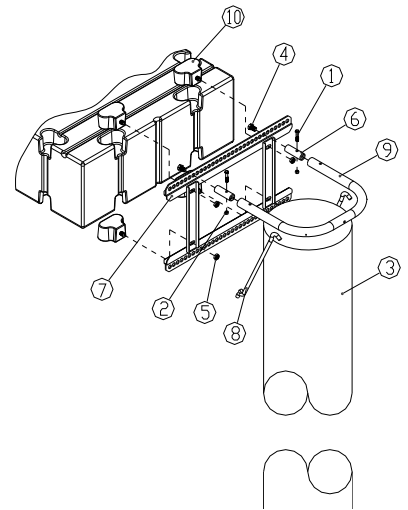

ITEM	QTY.	PART NO.	DESCRIPTION
1	2	80382	BOLT 3/8"-16 X 2"
2	2	80381	NUT 3/8"-16
3	1	N/A	PILING
4	2	80058	BOLT 5/8"-11 X 1 HHCS GRD 5
5	4	80580SS	NUT 5/8" SS
6	2	S10800	PILING GUSSET ARM
7	1	S10801	PILING HOOP INSERT
8	2	S10803	PILING HOOP BRACE GUSSET 21"
9	1	N/A	PILING HOOP
10	4	S21140SS	HDW CONNECTOR MALE 5/8" SS

Hoop Assembly Installation

1. Place hoop insert into the hole at the end of the hoop.
2. Insert 3/8"-16 X 2" hex bolt through top of hoop and hoop insert. Secure with 3/8"-16 hex nut.
3. Insert the hooked end of the hoop brace into the pre-drilled hole in the bottom of the hoop.
4. Rotate the brace clockwise until it fits snugly inside the hoop.
5. Center hoop assembly around the pile and insert ends of the hoop brace into the corresponding holes on the bottom of the piling bracket.
6. Apply pressure while pulling the hoop up and towards the dock until the ends of the hoop are flush with the top of the bracket.
7. Insert 5/8"-11 X 1" hex cap screws through the top holes of the bracket and into the threaded end of the hoop insert.

